

# TECHNICAL DATA SHEET

## F - 900 - 45 FRAME TOLERANCES

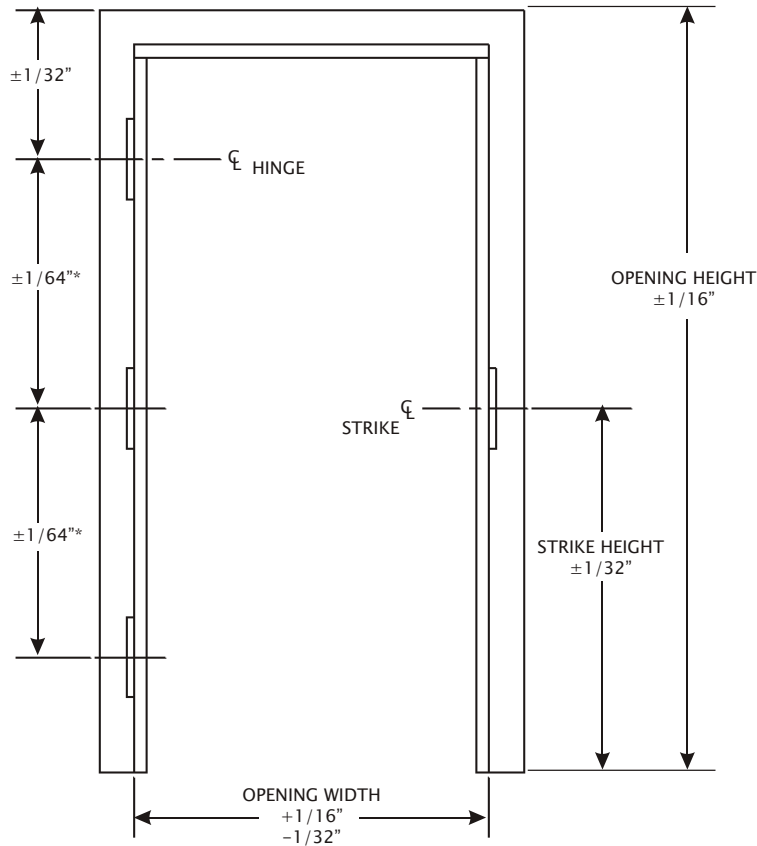

### HINGE PREPARATION

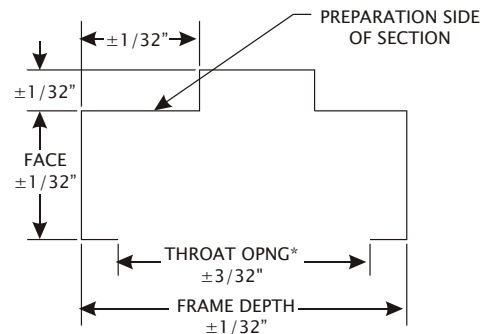
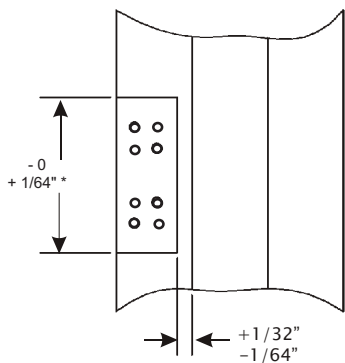

DRYWALL & MASONRY

\* TOLERANCES BETWEEN HINGE CENTERLINES ARE NON-ACCUMULATIVE

\*\*BASED ON NOMINAL HINGE HEIGHT  $+1/32"$   
ANSI A250-8

Issue Date: January 2006

REVISED : 02/01/2009

